

# HomeFill™ Ready Rack for Perfecto<sub>2</sub>™



Yes, you can.

## Concentrator

### Assembly, Installation and Operating Instructions

Model No. - For use with IRC5P and IRC5P2

#### SAVE THESE INSTRUCTIONS

*NOTE: Check all parts for shipping damage. In case of damage, DO NOT use. Contact the Carrier/Invacare for further instruction.*

## Safety Summary

### **⚠ WARNING**

**DO NOT** install this equipment without first reading and understanding this instruction sheet. If you are unable to understand the **Warnings, Cautions and Instructions** in this instruction sheet contact your **Home Healthcare Dealer** before attempting to install this equipment – otherwise injury or damage may result.

**DO NOT** move the concentrator while the HomeFill compressor is on the ready rack. Separate the HomeFill compressor from the ready rack prior to transporting.

Children should **ALWAYS** be supervised around the HomeFill unit. When used with the HomeFill ready rack or similar elevated support surfaces, a child could pull over any such stand causing the unit to fall. Failure to observe this warning may result in personal injury or product damage.

Invacare products are specifically designed and manufactured for use in conjunction with Invacare accessories. Accessories designed by other manufacturers have not been tested by Invacare and are not recommended for use with Invacare products.

### **CAUTION**

The HomeFill ready rack is designed for use with the Invacare Perfecto<sub>2</sub> concentrator and Invacare HomeFill compressor only. **DO NOT** attempt to use this ready rack with other products. Otherwise, damage to the ready rack and/or the other devices may occur.

## Assembly

The HomeFill ready rack requires no assembly and is provided in a ready for use condition.

For more information regarding Invacare products, parts, and services, please visit [www.invacare.com](http://www.invacare.com)

---

## Installing the HomeFill Ready Rack

*NOTE: For this procedure, refer to FIGURE 1 on page 3.*

1. Position the Invacare Perfecto<sub>2</sub> concentrator in the desired location.
2. Align the HomeFill ready rack above and toward the rear of the concentrator (Detail "A").
3. Move the ready rack forward until the rear pins fully engage the concentrator mounting holes (Detail "B").
4. Rotate the latch down over the handle to secure in place (Detail "B").
5. Orient and place the HomeFill compressor onto the installed ready rack as shown (Detail "C").

*NOTE: The HomeFill compressor will prevent the latch from becoming unsecured.*

6. Connect the HomeFill fill hose to the concentrator and compressor. Refer to Perfecto<sub>2</sub> owner's manual, part number 1143482, for proper connections.

## Transporting

---

### **WARNING**

**DO NOT move the concentrator while the HomeFill compressor is on the ready rack. Separate the HomeFill compressor from the ready rack prior to transporting.**

---

1. Disconnect the HomeFill unit from the concentrator and remove unit from the ready rack prior to transporting.

*NOTE: For operating instructions of the concentrator and/or HomeFill compressor, refer to Perfecto<sub>2</sub> owner's manual, part number 1143482, or HomeFill owner's manual, part number 1100873.*

---

**DETAIL "A" - ALIGNING THE READY RACK**

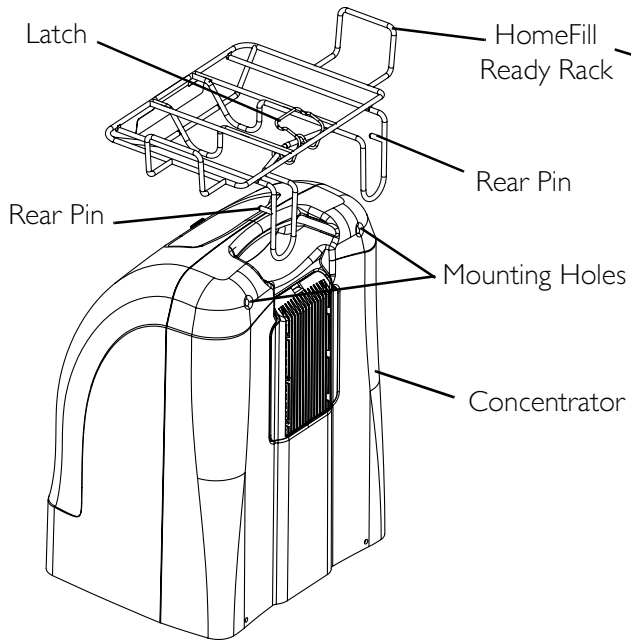

**DETAIL "B" - INSTALLING THE READY RACK**

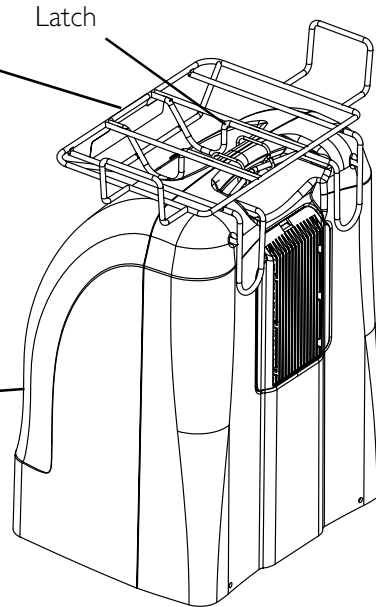

---

**DETAIL "C" - POSITIONING THE HOMEFILL ON THE READY RACK**

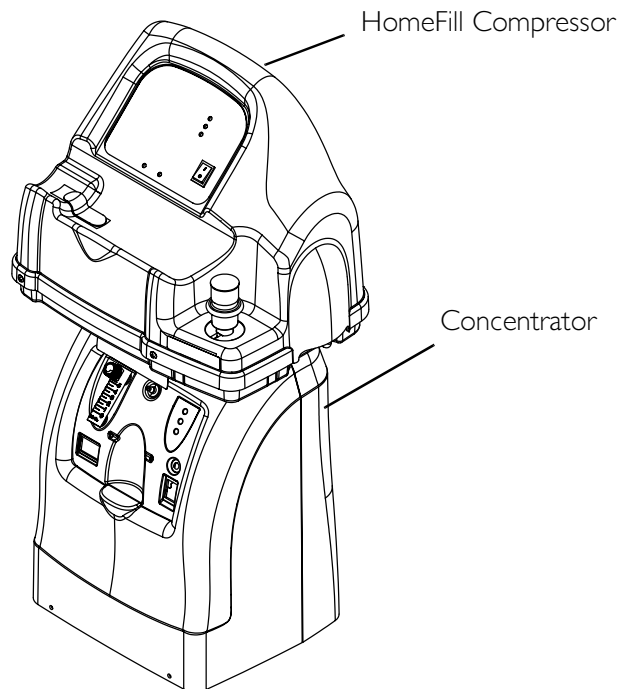

**FIGURE I** Installing the HomeFill Ready Rack

---

# LIMITED WARRANTY

**PLEASE NOTE: THE WARRANTY BELOW HAS BEEN DRAFTED TO COMPLY WITH FEDERAL LAW APPLICABLE TO PRODUCTS MANUFACTURED AFTER JULY 4, 1975.**

This warranty is extended only to the original purchaser/user of our products.

This warranty gives you specific legal rights and you may also have other legal rights which vary from state to state.

Invacare warrants its product to be free from defects in materials and workmanship for one year from the date of purchase for the original purchaser. If within such warranty period any such product shall be proven to be defective, such product shall be repaired or replaced, at Invacare's option. This warranty does not include any labor or shipping charges incurred in replacement part installation or repair of any such product. Invacare's sole obligation and your exclusive remedy under this warranty shall be limited to such repair and/or replacement.

For warranty service, please contact the dealer from whom you purchased your Invacare product. In the event you do not receive satisfactory warranty service, please write directly to Invacare at the address below. Provide dealer's name, address, model number, date of purchase, indicate nature of the defect and, if the product is serialized, indicate the serial number.

Invacare Corporation will issue a return authorization. The defective unit or parts must be returned for warranty inspection using the serial number, when applicable, as identification within thirty days of return authorization date. **DO NOT** return products to our factory without our prior consent. C.O.D. shipments will be refused; please prepay shipping charges.

**LIMITATIONS AND EXCLUSIONS: THE WARRANTY SHALL NOT APPLY TO PROBLEMS ARISING FROM NORMAL WEAR OR FAILURE TO ADHERE TO THE ENCLOSED INSTRUCTIONS. IN ADDITION, THE FOREGOING WARRANTY SHALL NOT APPLY TO SERIAL NUMBERED PRODUCTS IF THE SERIAL NUMBER HAS BEEN REMOVED OR DEFACED; PRODUCTS SUBJECTED TO NEGLIGENCE, ACCIDENT, IMPROPER OPERATION, MAINTENANCE OR STORAGE; OR PRODUCTS MODIFIED WITHOUT INVACARE'S EXPRESS WRITTEN CONSENT INCLUDING, BUT NOT LIMITED TO: MODIFICATION THROUGH THE USE OF UNAUTHORIZED PARTS OR ATTACHMENTS; PRODUCTS DAMAGED BY REASON OF REPAIRS MADE TO ANY COMPONENT WITHOUT THE SPECIFIC CONSENT OF INVACARE; PRODUCTS DAMAGED BY CIRCUMSTANCES BEYOND INVACARE'S CONTROL; PRODUCTS REPAIRED BY ANYONE OTHER THAN AN INVACARE DEALER, SUCH EVALUATION SHALL BE SOLELY DETERMINED BY INVACARE. IN NO EVENT SHALL INVACARE BE LIABLE FOR ANY CONSEQUENTIAL OR INCIDENTAL DAMAGES WHATSOEVER. THE FOREGOING EXPRESS WARRANTY IS EXCLUSIVE AND IN LIEU OF ANY OTHER WARRANTIES WHATSOEVER, WHETHER EXPRESS OR IMPLIED, INCLUDING THE IMPLIED WARRANTIES OF MERCHANTABILITY AND FITNESS FOR A PARTICULAR PURPOSE, AND THE SOLE REMEDY FOR VIOLATIONS OF ANY WARRANTY WHATSOEVER, SHALL BE LIMITED TO REPAIR OR REPLACEMENT OF THE DEFECTIVE PRODUCT PURSUANT TO THE TERMS CONTAINED HEREIN. THE APPLICATION OF ANY IMPLIED WARRANTY WHATSOEVER SHALL NOT EXTEND BEYOND THE DURATION OF THE EXPRESS WARRANTY PROVIDED HEREIN. INVACARE SHALL NOT BE LIABLE FOR ANY CONSEQUENTIAL OR INCIDENTAL DAMAGES WHATSOEVER. THIS WARRANTY SHALL BE EXTENDED TO COMPLY WITH STATE/PROVINCIAL LAWS AND REQUIREMENTS.**

Invacare Corporation [www.invacare.com](http://www.invacare.com)



*Yes, you can.*

**USA**  
One Invacare Way  
Elyria, Ohio USA  
44036-2125  
800-333-6900  
Technical Support:  
800-832-4707

Invacare, Yes, you can. and the Medallion Design are registered trademarks of Invacare Corporation.  
HomeFill and Perfecto<sub>2</sub> are trademarks of the Invacare Corporation.  
© 2007 Invacare Corporation

Part No 1148363 Rev A - 2/21/07